

Fuzing & Ordnance Systems

XM1162

PYROTECHNIC SELF-DESTRUCT FUZE

XM1162 FEATURES

User Base

- Pyrotechnic Self-Destruct Fuze for U.S. Armed Forces DPICM applications in 155mm artillery and Guided Multiple Launch Rocket System (GMLRS)

Safety

- Redundant safeties for handling during Load, Assemble and Pack (LAP) operations
- Out-of-line explosive train prior to cargo dispense

Operation

- Independent Self-Destruct (SD) mode
- SD time delay is 24 seconds
- -50°F to 145°F operating temperature
- Compatible with M42, M46 and M77 grenades
- Functions in both spin and non-spin environments

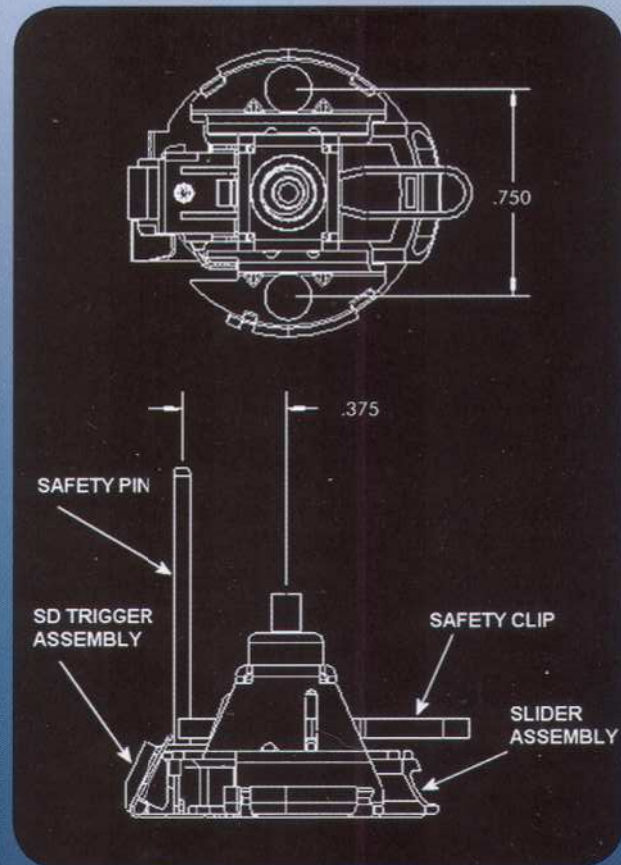

FUZING & ORDNANCE SYSTEMS

1650 Manheim Pike, Suite 201

Lancaster, PA 17601-3088

P: 717-735-0300

F: 717-397-8510

www.L-3com.com/FOS



Fuzing & Ordnance Systems

Headquartered in New York City, L-3 Communications employs over 64,000 people worldwide and is a prime contractor in aircraft modernization and maintenance, C³ISR (Command, Control, Communications, Intelligence, Surveillance and Reconnaissance) systems and government services. L-3 is also a leading provider of high technology products, subsystems and systems.

Data contained within this document are summary in nature and subject to change at any time at L-3 Communications' discretion.

XM1162

PYROTECHNIC SELF-DESTRUCT FUZE

The XM1162 pyrotechnic Self-Destruct Fuze (p-SDF) is a grenade fuze designed to minimize battlefield duds by adding a self-destruct capability to the current Dual Purpose Improved Conventional Munitions (DPICM).



PRODUCT DESCRIPTION

The XM1162 p-SDF is designed for use in both artillery and rocket applications. The p-SDF primary function mode is based on the M223E1 design.

The self-destruct system contains a pyrotechnic time delay that is initiated at grenade expulsion. The pyrotechnic system is independent of the primary mode. It is designed to function whether or not the fuze slider (containing the out-of-line detonator) has moved to the armed position.



M864E2 PROJECTILE

155MM: EXTENDED RANGE, DP

M864E2 Projectile with XM1162 pyrotechnic Self-Destruct Fuze submissions for 155mm howitzers.

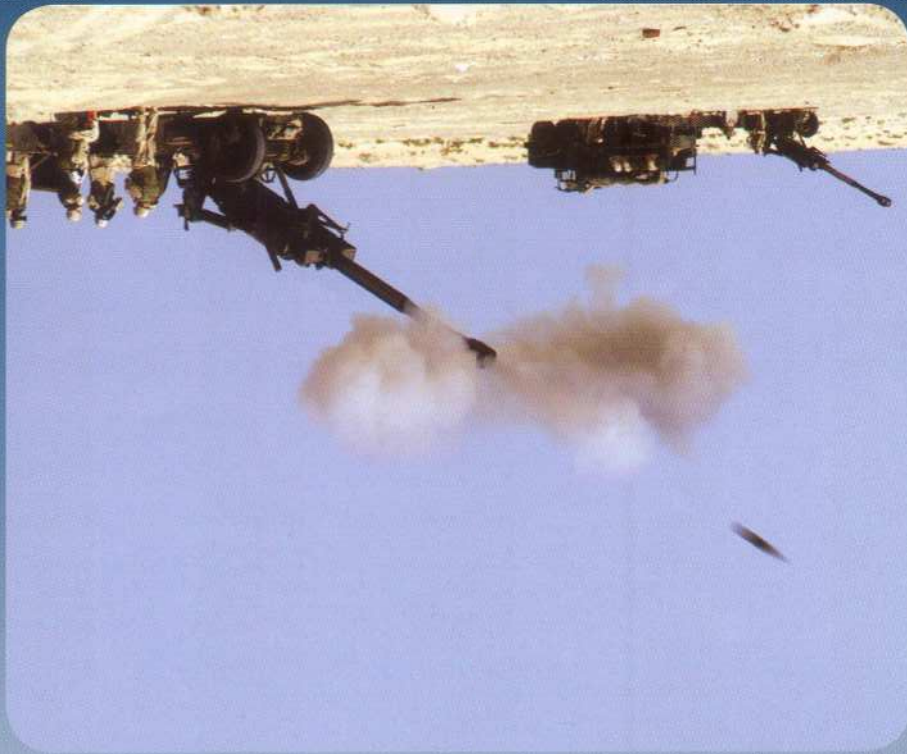

PRODUCT DESCRIPTION

The M864E2 Projectile is used to deliver dual purpose armor defeating and anti-personnel grenades for extended ranges beyond the capability of the M483E2 Projectile or when the M483E2 Projectile is not available.



